

Instructions

Extend Card (Alarm in)

Model No. **WJ-PB85A32**

Before attempting to connect or install this product, please read these instructions carefully and save this manual for future use.

Caution

Hold this board only by its edges. Otherwise components on the board may be damaged by static electricity.

■ Preface

The WJ-PB85A32 Alarm Input Board is an optional board for expanding the capabilities of the System 850 Matrix Switcher.

It transmits a received alarm signal to the CPU (Central Processing Unit) via Ethernet to activate the assigned alarm event.

The board can also be used as an alarm output board by changing the position of internal switches.

■ Appearance

① Alarm Input Port (1 - 32)

This port accepts alarm input from the associated alarm sensors through either Normally Open (N.O) or Normally Closed (N.C) contacts.

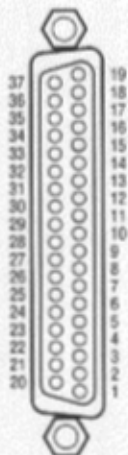

Pin No.	Designation	Pin No.	Designation
37	Ground	19	Alarm 19
36	Ground	18	Alarm 18
35	Not used	17	Alarm 17
34	Not used	16	Alarm 16
33	Not used	15	Alarm 15
32	Alarm 32	14	Alarm 14
31	Alarm 31	13	Alarm 13
30	Alarm 30	12	Alarm 12
29	Alarm 29	11	Alarm 11
28	Alarm 28	10	Alarm 10
27	Alarm 27	9	Alarm 9
26	Alarm 26	8	Alarm 8
25	Alarm 25	7	Alarm 7
24	Alarm 24	6	Alarm 6
23	Alarm 23	5	Alarm 5
22	Alarm 22	4	Alarm 4
21	Alarm 21	3	Alarm 3
20	Alarm 20	2	Alarm 2
		1	Alarm 1

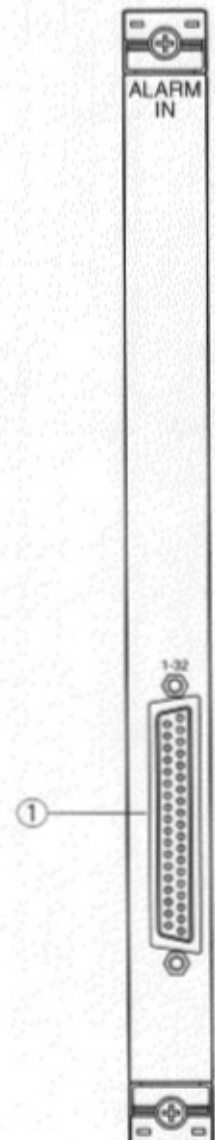

Board Setting

Before installing this board, the following settings should be made by qualified service personnel or system installers.

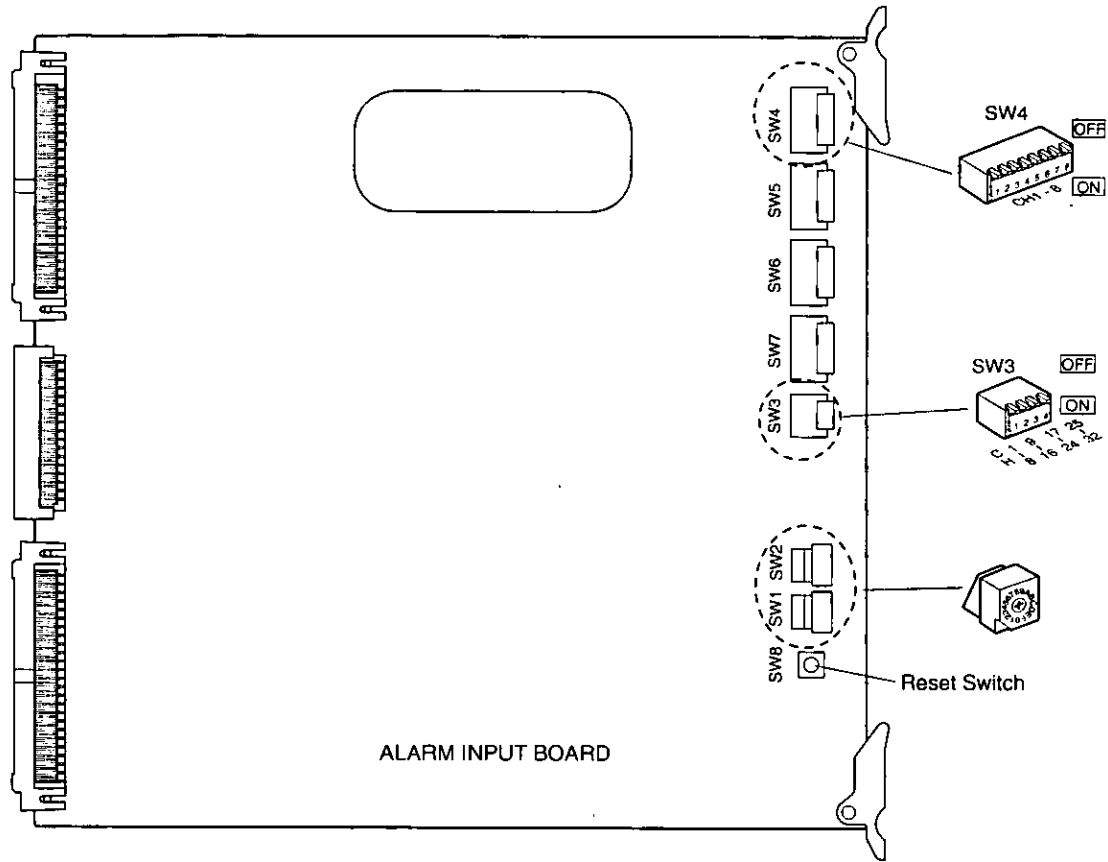

- Set switches (SW1 and SW2) on the board to designate the Alarm Input board number as shown in the following table. The factory default setting is Board Number 1 (00).

Board No.	Alarm Input	SW Positions	
		SW2	SW1
1	1 - 32	0	0
2	33 - 64	0	1
3	65 - 96	0	2
4	97 - 128	0	3
5	129 - 160	0	4
6	161 - 192	0	5
7	193 - 224	0	6
8	225 - 256	0	7
9	257 - 288	0	8
10	289 - 320	0	9
11	321 - 352	0	A
12	353 - 384	0	B
13	385 - 416	0	C
14	417 - 448	0	D
15	449 - 480	0	E
16	481 - 512	0	F

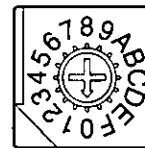

- Set switches (SW4, SW5, SW6, and SW7) on the board to meet the alarm input requirements.

ON: Normally Closed (N.C)
 OFF: Normally Open (N.O)

The factory default settings are OFF.

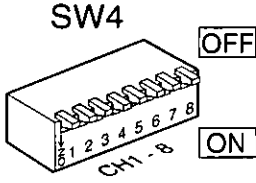

- If this board is used for Alarm Output, set switches (SW3) on the board as follows.

ON: Output mode
 OFF: Input mode

The factory default settings are OFF.

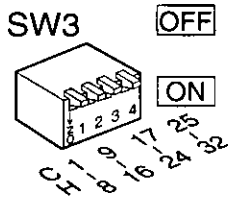

Installation

The following installation should be made by qualified service personnel or system installers.

Installing Additional Extension Boards

- Remove the screws from the rear panel(s) of the WJ-SX850 Matrix Switcher Card Cage.

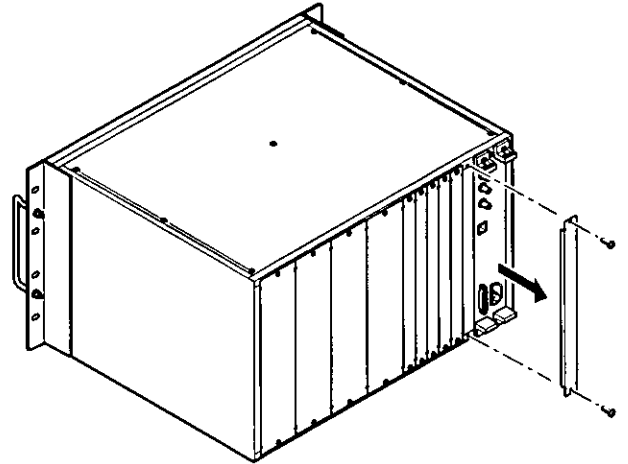

- Remove the rear panel(s).
- Remove the front panel of the cage by removing the two screws on the panel shown below.

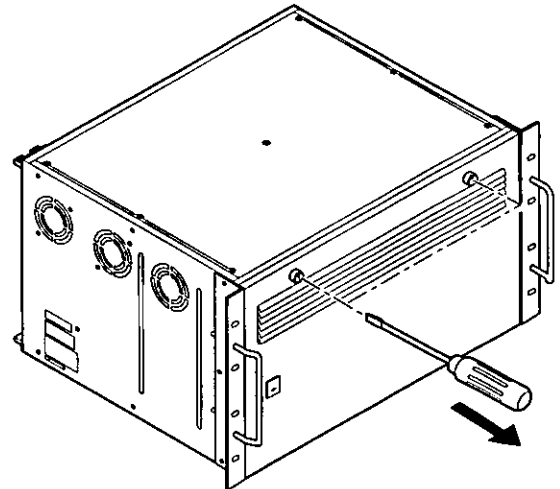

4. Place the Boards into the specified positions in the front or rear of the Cage by sliding them along the board guides as shown below.

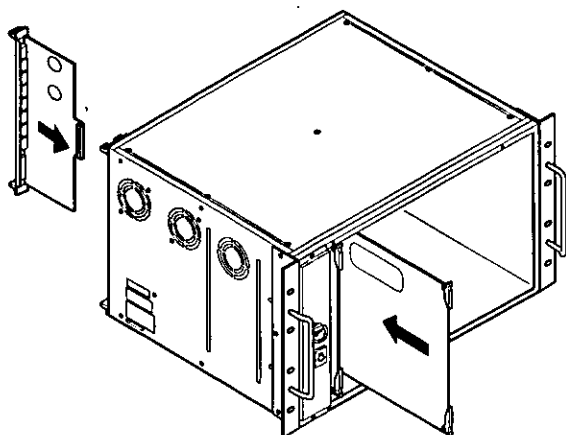

5. Make sure to push in the Boards until they are seated firmly.

6. Secure the rear board by tightening the two screws on the board.

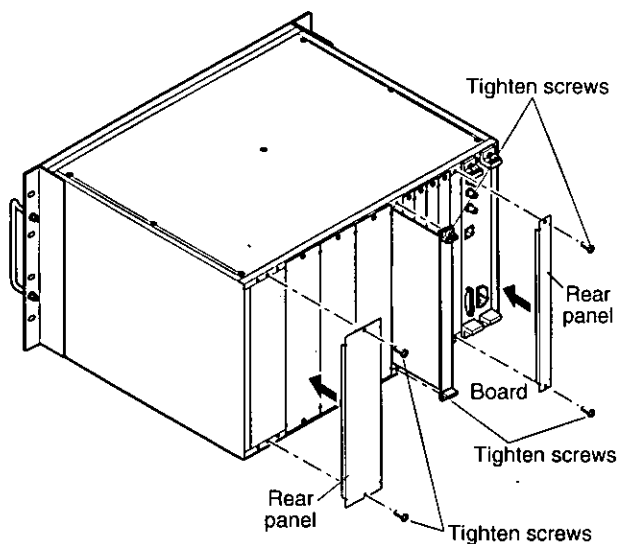

7. Close open spaces on the rear of the Cage with the supplied rear panel(s).

8. Close the front of the cage by fixing the front panel.

■ Specifications

Alarm Input (1 - 32):

Normally Open or Normally Closed selectable
37-pin D-sub connector

(Alarm Output):

Open Collector Output, 12 V DC 50 mA maximum

Dimensions:

Front Board: 255(W) x 250(H) x 12(D) mm
10-1/16"(W) x 9-13/16"(H) x 1/2"(D)
Rear Board: 117.5(W) x 265(H) x 20(D) mm
4-5/8"(W) x 10-7/16"(H) x 13/16"(D)

Weight:

0.5 kg (1.1 lbs)

Weight and dimensions indicated are approximate.
Specifications are subject to change without notice.

Panasonic Security and Digital Imaging Company

A Division of Matsushita Electric Corporation of America

Executive Office: One Panasonic Way 3E-7, Secaucus, New Jersey 07094

Regional Offices:

Northeast: One Panasonic Way, Secaucus, NJ 07094 (201) 348-7303

Southern: 1225 Northbrook Parkway, Suite 1-160, Suwanee, GA 30024 (770) 338-6838

Midwest: 1707 North Randall Road, Elgin, IL 60123 (847) 468-5211

Western: 6550 Katella Ave., Cypress, CA 90630 (714) 373-7840

Panasonic Canada Inc.

5770 Ambler Drive, Mississauga,
Ontario, L4W 2T3 Canada (905)624-5010

Panasonic Sales Company

Division of Matsushita Electric of Puerto Rico Inc.

Ave. 65 de Infanteria. Km. 9.5
San Gabriel Industrial Park, Carolina,
Puerto Rico 00985 (809)750-4300